



Kenya Power

TITLE:

**SPECIFICATION FOR
PULLING AND LIFTING
MACHINES**

Part 1: Conductor Tensioner and
Come Along Clamps

Doc. No. KP1/3CB/TSP/09/061-1

Issue No. 1

Revision No. 0

Date of Issue 2014-08-08

Page 1 of 11

TABLE OF CONTENTS

0.1 Circulation List

0.2 Amendment Record

FOREWORD

1. SCOPE
2. REFERENCES
3. TERMS AND DEFINITIONS
4. REQUIREMENTS
5. TESTS AND INSPECTION
6. MARKING AND PACKING
7. DOCUMENTATION

ANNEX A: *Guaranteed Technical Particulars (to be filled and signed by the Manufacturer and submitted together with relevant copies of the Manufacturer's catalogues, brochures, drawings, technical data, sales records for previous five years, four customer reference letters, details of manufacturing capacity, the manufacturer's experience and copies of complete type test certificates and type test reports for tender evaluation, all in English Language)*

Issued by: Head of Section Tech Stds & Specs

Authorized by: Head of Department, R & D

Signed:

Signed:

Date: 2014-08-08

Date: 2014-08-08



Kenya Power

TITLE:

**SPECIFICATION FOR
PULLING AND LIFTING
MACHINES**

Part 1: Conductor Tensioner and
Come Along Clamps

Doc. No.

KP1/3CB/TSP/09/061-1

Issue No.

1

Revision
No.

0

Date of
Issue

2014-08-08

Page 2 of 11

0.1 Circulation List

COPY NO.	COPY HOLDER
1	Research & Development Manager
2	Supply Chain Manager (Procurement)
Electronic copy (pdf) on Kenya Power server (http://172.16.1.40/dms/browse.php?fFolderId=23)	

0.2 Amendment Record

Rev No.	Date (YYYY-MM-DD)	Description of Change	Prepared by (Name & Signature)	Approved by (Name & Signature)
0	2014-08-08	New Issue	Michael Apudo 	Eng. Simon Kimitei

Issued by: Head of Section Tech Stds & Specs

Signed:

Date: 2014-08-08

Authorized by: Head of Department, R & D

Signed:

Date: 2014-08-08



Kenya Power

TITLE:

**SPECIFICATION FOR
PULLING AND LIFTING
MACHINES**

Part 1: Conductor Tensioner and
Come Along Clamps

Doc. No. KP1/3CB/TSP/09/061-1

Issue No. 1

Revision No. 0

Date of Issue 2014-08-08

Page 3 of 11

FOREWORD

This specification has been prepared by the Research and Development Department in collaboration with Distribution Division, both of The Kenya Power and Lighting Company Limited (KPLC) and it lays down requirements for pulling and lifting machines (conductor tensioner and come along clamps) for use on distribution power lines. It is intended for use by KPLC in purchasing the items.

1. SCOPE

1.1. This specification covers pulling and lifting machines for use on distribution power lines and with the following devices:

- a) Conductor Tensioner
 - (i) **Type 1** - 15 to 19 mm and pulling force of 8kN
 - (ii) **Type 2** - 7 to 14mm and pulling force of 6kN
- b) Come-Along Clamps For Aluminium Conductors

1.2. The specification also covers inspection and test of the conductor tensioner and come along clamps as well as schedule of Guaranteed Technical Particulars to be filled, signed by the manufacturer and submitted for tender evaluation.

1.3. The specification stipulates the minimum requirements for conductor tensioner and come along clamps; acceptable for use in the company and it shall be the responsibility of the supplier to ensure adequacy of the design, good engineering practice, adherence to the specification and applicable standards and regulations as well as ensuring good workmanship in the manufacture of the conductor tensioner and come along clamps for The Kenya Power & Lighting Company.

The specification does not purport to include all the necessary provisions of a contract.

2. REFERENCES

The following standards contain provisions which, through reference in this text constitute provisions of this specification. Unless otherwise stated, the latest editions (including amendments) apply:

ISO 3077: Short link chain for lifting purposes - Grade T (Types T, DAT and DT), fine-tolerance hoist chain.

ISO 1461: Hot dip galvanizing coatings on fabricated iron and steel articles. Specification and test methods

Issued by: Head of Section Tech Stds & Specs

Signed:

Date: 2014-08-08

Authorized by: Head of Department, R & D

Signed:

Date: 2014-08-08



Kenya Power

TITLE:

**SPECIFICATION FOR
PULLING AND LIFTING
MACHINES**

Part 1: Conductor Tensioner and
Come Along Clamps

Doc. No. KP1/3CB/TSP/09/061-1

Issue No. 1

Revision No. 0

Date of Issue 2014-08-08

Page 4 of 11

BS EN 1706: Aluminium and aluminium alloys. Castings. Chemical composition and mechanical properties.

3. TERMS AND DEFINITIONS

For the purposes of this specification the definitions given in the reference standards shall apply.

4. REQUIREMENTS

4.1. SERVICE CONDITIONS

The conductor tensioner and come along clamps shall be tropicalized, designed and constructed for continuous outdoor operation in tropical areas and harsh climatic conditions including areas exposed to:

- (i) Sea spray (along the coast),
- (ii) Humidity of up to 95% and
- (iii) Average ambient temperature of +30°C with a minimum of -1°C and a maximum of +40°C.
- (iv) Altitudes of up to 2000m above the sea level.

4.2. PARTICULAR REQUIREMENTS

4.2.1. Conductor Tensioner

- 4.2.1.1. This shall be a cable, conductor and wire rope tensioning device for tensioning electric cables and conductors in long span lines during construction of power lines and it shall be as per Fig. 1.
- 4.2.1.2. It shall be made from a lightweight high strength aluminium alloy designation LM4, tensile strength of 280 N/mm² conforming to BS EN 1706 standard, easy to handle and compact. The conductor tensioner shall be equipped with interchangeable self-gripping cams and its anchoring chain rope.
- 4.2.1.3. The chain rope shall be manufactured from steel Grade T as per ISO 3077: 2001. The steel used shall be produced by the electric process or by an oxygen-blown process and shall be fully killed in conformity with a suitable deoxidation process in order to obtain an austenitic grain size of 5 or finer when tested in accordance with ISO 643.

Issued by: Head of Section Tech Stds & Specs

Signed:

Date: 2014-08-08

Authorized by: Head of Department, R & D

Signed:

Date: 2014-08-08



Kenya Power

TITLE:

**SPECIFICATION FOR
PULLING AND LIFTING
MACHINES**

Part 1: Conductor Tensioner and
Come Along Clamps

Doc. No. KP1/3CB/TSP/09/061-1

Issue No. 1

Revision No. 0

Date of Issue 2014-08-08

Page 5 of 11

- 4.2.1.4. The handle of the conductor tensioner shall be made from a suitable plastic material to offer grip comfort during operation.
- 4.2.1.5. The conductor tensioner shall be supplied complete with all relevant accessories and grips, designed according to the same principle as the strainer self-gripping jaws; they shall easily maintain the tension in the cables while joining and adjusting cable operations.
- 4.2.1.6. It shall have the ability to be put at work and disengage instantaneously on releasing the tension.
- 4.2.1.7. The conductor tensioner under this specification shall be categorized in two major sizes namely:
- a) Universal light alloy wire-strainer – Type 1, suitable for tightening and pulling cables with diameters ranging from 15 to 19mm, with a pulling force of 8kN. Its total weight shall not exceed 6.5 kg
 - b) Universal light alloy wire-strainer – Type 2, suitable for tightening and pulling cables with diameters ranging from 7 to 14 mm, with a pulling force of 6kN. It shall be put at work or disengaged instantaneously. Its total weight shall not exceed 5.5 kg.

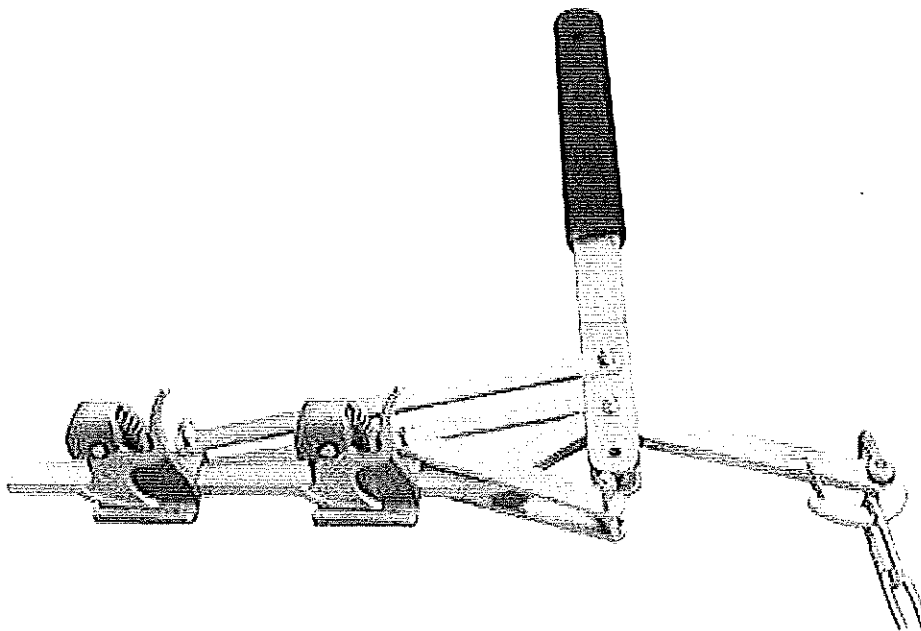

Fig 1: General Arrangement – Conductor Tensioner with anchoring rope.

Issued by: Head of Section Tech Stds & Specs

Signed:

Date: 2014-08-08

Authorized by: Head of Department, R & D

Signed:

Date: 2014-08-08



Kenya Power

TITLE:

**SPECIFICATION FOR
PULLING AND LIFTING
MACHINES**

Part 1: Conductor Tensioner and
Come Along Clamps

Doc. No.

KP1/3CB/TSP/09/061-1

Issue No.

1

Revision
No.

0

Date of
Issue

2014-08-08

Page 6 of 11

4.2.2. Come-Along Clamps for Al Conductors

- 4.2.2.1. The self-gripping clamps shall be used to anchor and to string conductors (aluminium, ACSR...) and steel ropes.
- 4.2.2.2. The body shall be made of high strength heat forged steel conforming to any grade of PD 970:2005 standard, in order to minimize the ratio between weight and working load.
- 4.2.2.3. The clamp ferric parts shall be hot dip galvanized as per ISO 1461 standard with minimum thickness of zinc of 80µm. The galvanization treatment on the surface protects them from oxidation.
- 4.2.2.4. The clamps design shall have a provision for machined body clamps or with interchangeable jaws to offer the ability to use the same clamp while working on conductors, ropes or OPGW of different diameters by only changing the jaws.
- 4.2.2.5. This feature shall help reduce on operating costs. The clamps shall also accept a large range of rope and conductor diameters by using a small number of interchangeable or machined jaws
- 4.2.2.6. The clamps ratings shall be as given in Table 1. This shall be stated in the tender.

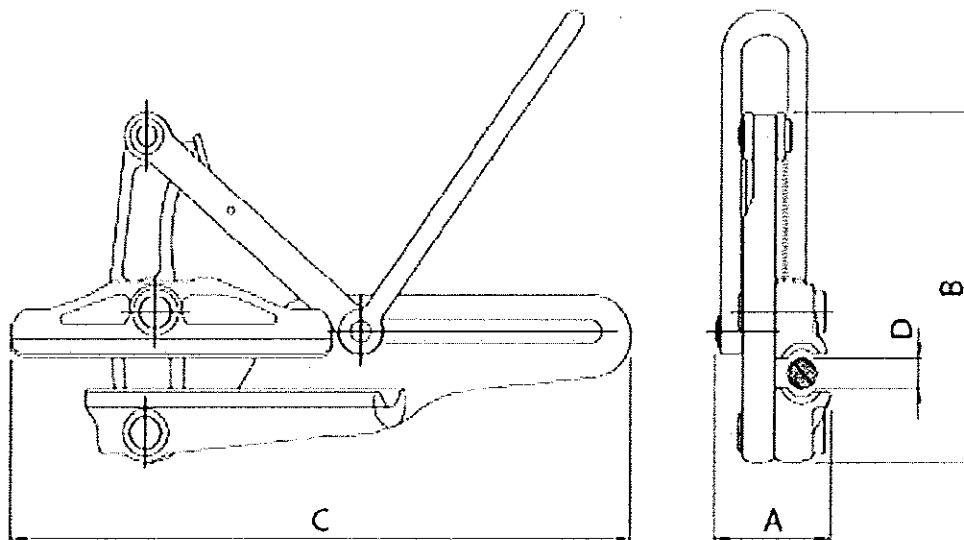

Fig. 2: Come-Along Clamps

Issued by: Head of Section Tech Stds & Specs

Authorized by: Head of Department, R & D

Signed:

Signed:

Date: 2014-08-08

Date: 2014-08-08



Kenya Power

TITLE:

**SPECIFICATION FOR
PULLING AND LIFTING
MACHINES**

Part 1: Conductor Tensioner and
Come Along Clamps

Doc. No. KP1/3CB/TSP/09/061-1

Issue No. 1

Revision No. 0

Date of Issue 2014-08-08

Page 7 of 11

Table 1: Dimensional and weight properties

Dimensions in mm			Breaking load kN	Maximum working load kN	Mass Kg	Use Steel rope	Diameter range in mm D
A	B	C					
80	225	380	125	42	7	Yes	8 - 18
100	300	535	225	75	15	Yes	18 - 24
100	300	535	225	75	15	Yes	24 - 28
114	353	604	280	93	19.5	Yes	27 - 32

4.3. Quality Management System

- 4.3.1. The supplier shall submit a quality assurance plan (QAP) that will be used to ensure that the design, material, workmanship, tests, service capability, maintenance and documentation of the conductor tensioner and come along clamps fulfil the requirements stated in the contract documents, standards, specifications and regulations. The QAP shall be based on and include relevant parts to fulfil the requirements of ISO 9001:2008.
- 4.3.2. The Manufacturer's Declaration of Conformity to applicable standards and copies of quality management certifications including copy of valid and relevant ISO 9001:2008 certificate shall be submitted with the tender for evaluation.
- 4.3.3. The bidder shall indicate the delivery time of the conductor tensioner and come along clamps, manufacturer's monthly & annual production capacity and experience in the production of the type and size of items being offered.

5.0. TESTS AND INSPECTION

- 5.1. The conductor tensioner and come along clamps shall be inspected and tested in accordance with the requirements of the respective standards and all the provisions of this specification. It shall be the responsibility of the supplier to perform or to have performed the tests specified and whatever other tests he normally performs at works.
- 5.2. Copies of previous Type Test Reports issued by a third party testing laboratory that is accredited to ISO/IEC 17025 shall be submitted with the tender for the purpose of technical evaluation. The accreditation certificate to ISO/IEC 17025 for the same third party testing laboratory used shall also be submitted with the tender document (all in English Language)

Issued by: Head of Section Tech Stds & Specs

Authorized by: Head of Department, R & D

Signed:

Signed:

Date: 2014-08-08

Date: 2014-08-08



Kenya Power

TITLE:

**SPECIFICATION FOR
PULLING AND LIFTING
MACHINES**

Part 1: Conductor Tensioner and
Come Along Clamps

Doc. No. KP1/3CB/TSP/09/061-1

Issue No. 1

Revision No. 0

Date of Issue 2014-08-08

Page 8 of 11

5.3. The conductor tensioner and come along clamps shall be subject to acceptance tests at the manufacturer's works before dispatch. Acceptance tests shall be witnessed by two Engineers appointed by The Kenya Power and Lighting Company Limited (KPLC). Routine and Sample Test Reports for the conductor tensioner and come along clamps to be supplied shall be submitted to KPLC for approval before delivery of the goods.

5.4. On receipt of the product, KPLC will perform any of the tests specified in order to verify compliance with this specification. The supplier shall replace without charge to KPLC the conductor tensioner and come along clamps which upon examination, test or use; fail to meet any of the requirements in the specification.

6.0. MARKING AND PACKING

6.1. MARKINGS

All conductor tensioner and come along clamps shall be permanently marked with a manufactures trademark and a serial number for traceability in English Language.

- a) Standard of manufacture
- b) Identity of the manufacturer
- c) Type reference number
- d) Words "**PROPERTY OF KPLC**"

6.2. PACKAGING

6.2.1. The conductor tensioner and come along clamps shall be packed in such a manner so as to avoid damage during transportation and storage.

6.2.2. The conductor tensioner and come along clamps shall be packaged in a waterproof storage bags that help guard against contaminants and abrasion..

6.2.3. The following information shall be printed on a suitable label firmly attached to each packaging:

- a) Purchase order number/tender number
- b) Manufacturer's name
- c) Year of manufacture
- d) The words, "**PROPERTY OF KENYA POWER & LIGHTING CO. LTD.**"

Issued by: Head of Section Tech Stds & Specs

Authorized by: Head of Department, R & D

Signed:

Signed:

Date: 2014-08-08

Date: 2014-08-08



Kenya Power

TITLE:

**SPECIFICATION FOR
PULLING AND LIFTING
MACHINES**

Part 1: Conductor Tensioner and
Come Along Clamps

Doc. No.

KP1/3CB/TSP/09/061-1

Issue No.

1

Revision
No.

0

Date of
Issue

2014-08-08

Page 9 of 11

7. DOCUMENTATION

7.1 The bidder shall submit its tender complete with technical documents required by Annex A (Guaranteed Technical Particulars) for tender evaluation. The technical documents to be submitted (all in English language) for tender evaluation shall include the following:

- a) Guaranteed Technical Particulars signed by the manufacturer;
- b) Copies of the Manufacturer's catalogues, brochures, drawings and technical data for the item;
- c) Sales records for the last five years and at least four customer reference letters;
- d) Details of manufacturing capacity and the manufacturer's experience;
- e) Copies of required type test reports by a third party testing laboratory accredited to ISO/IEC 17025;
- f) Copy of accreditation certificate to ISO/IEC 17025 for the third party testing laboratory;
- g) Manufacturers letter of authorization, ISO 9001:2008 certificate and other technical documents required in the tender.

7.2 The successful bidder (supplier) shall submit the following documents/details to The Kenya Power & Lighting Company for approval before manufacture:

- a) Guaranteed Technical Particulars signed by the manufacturer;
- b) Design Drawings with details of conductor tensioner and come along clamps to be manufactured for KPLC.
- c) Quality assurance plan (QAP) that will be used to ensure that the design, material; workmanship, tests, service capability, maintenance and documentation will fulfill the requirements stated in the contract documents, standards, specifications and regulations. The QAP shall be based on and include relevant parts to fulfill the requirements of ISO 9001:2008
- d) Detailed test program to be used during factory testing;
- e) Marking details and method to be used in marking the conductor tensioner and come along clamps;
- f) Manufacturer's undertaking to ensure adequacy of the design, good engineering practice, adherence to the specification and applicable standards and regulations as well as ensuring good workmanship in the manufacture of the conductor tensioner and come along clamps for The Kenya Power & Lighting Company;
- g) Packaging details (including packaging materials).

7.3 The supplier shall submit recommendations for use, care, storage and routine inspection/testing procedures, all in the English Language, during delivery of the conductor tensioner and come along clamps to KPLC stores.

Issued by: Head of Section Tech Stds & Specs

Authorized by: Head of Department, R & D

Signed:

Signed:

Date: 2014-08-08

Date: 2014-08-08



Kenya Power

TITLE:

**SPECIFICATION FOR
PULLING AND LIFTING
MACHINES**

Part 1: Conductor Tensioner and
Come Along Clamps

Doc. No.	KP1/3CB/TSP/09/061-1
Issue No.	1
Revision No.	0
Date of Issue	2014-08-08
Page 10 of 11	

ANNEX A: Guaranteed Technical Particulars (to be filled and signed by the Supplier and submitted together with copies of manufacturer's catalogues, brochures, drawings, technical data, sales records, customer reference letters and copies of certificates/test reports for tender evaluation)

Tender No.

Clause number	Bidder's offer (indicate full details of the offered item for each requirement of the tender & specification)
Bidder's Name	
Manufacturer's Name, address and country	
Type reference/model number of item(s) offered	
Scope: 1.1	
1.2 Conductor tensioning and stringing devices	
a) Conductor Tensioner	
(i) 15 to 19 mm and pulling force of 8kN	
(ii) 7 to 14mm and pulling force of 6kN	
b) Come-Along Clamps for Aluminium Conductors	
1.3.	
1.4	
2.0 Applicable Standards (References)	
3.0 Terms & definitions	
4.0 Requirements	
4.1 Service conditions	
4.2 Particular requirements	
4.2.1 Conductor tensioner	
4.2.1.1 - 4.2.1.7.	
4.2.2 Come Along Clamps	
4.2.2.1 – 4.2.2.6	
4.3 Quality Management System	
5.0 Tests and Inspection	
5.1 – 5.4	
6.0 Marking and Packing	
6.1 Packing	
6.1.1	
6.1.2	
6.2 Marking	
6.2.1	

Issued by: Head of Section Tech Stds & Specs

Signed:

Date: 2014-08-08

Authorized by: Head of Department, R & D

Signed:

Date: 2014-08-08



Kenya Power

TITLE:

**SPECIFICATION FOR
PULLING AND LIFTING
MACHINES**

Part 1: Conductor Tensioner and
Come Along Clamps

Doc. No.

KP1/3CB/TSP/09/061-1

Issue No.

1

Revision
No.

0

Date of
Issue

2014-08-08

Page 11 of 11

6.2.2	
7.0 Documentation	
7.1 Completed tender document	
7.2 Catalogues, brochures, drawings & technical data submitted with offer	
8.0. Manufacturer's Guarantee and Warranty	
9.0 List catalogues, brochures, technical data and drawings submitted to support the offer.	
10.0 List customer sales records and reference letters submitted to support the offer.	
11.0 List Test Certificates submitted with tender	
12.0 List test reports of conductor tensioner and come along clamps to be submitted to KPLC for approval before shipment	
13.0 Statement of compliance to specification (indicate deviations if any & supporting documents)	

.....
Supplier's Name, Signature, Stamp and Date

Issued by: Head of Section Tech Stds & Specs

Authorized by: Head of Department, R & D

Signed:

Signed:

Date: 2014-08-08

Date: 2014-08-08

